



# Catalogue

Reliable made affordable





## About Himel

Himel is a multinational manufacturer and provider of electrical products successfully combining global expertise with local knowledge.

Founded by a Spanish entrepreneur in 1958, the company pioneered in exporting quality electrical enclosures, establishing Himel brand globally. Today, our global footprint and technology enable us to provide the best combination of affordable and reliable offers for Low Voltage Power distribution, Industry Automation and Home Electric to our long-term customers and partners in over 50 countries where we are present.

**Himel. Reliable made affordable**



## HDM3E Molded Case Circuit Breaker(Electronic)

Product selection  
Standard:IEC/EN 60947-2



Reference HDM3E125M12533XXP7

HD	M3E	125	M	125	3	3	XX
Code	A	B	C	D	E	F	G
	Product	Frame Current	Breaking Capacity	Rated Current	Pole	Tripping Type	Product accessory
Description	HDM3E	125	M	125	3	3	XX
	HDM3E	125: 125A 250: 250A 400: 400A 630: 630A 800: 800A 16X: 1600A <sup>2)</sup>	M: 50kA	125: 125A 250: 250A 400: 400A 630: 630A 800: 800A 16X: 1600A	3: 3 Pole C: 4 Pole(with tripping release, N phase can open and close) D: 4 Pole(without tripping release, N phase connection directly)	3: Electronic tripping	XX:No accessory 08:Alarm 10:Shunt release <sup>4)</sup> 18:Shunt release+alarm <sup>4)</sup> 20:Single auxiliary 28: Auxiliary alarm 30:Under-voltage release <sup>6)</sup> 38:Under-voltage release+alarm <sup>6)</sup> 40:Shunt release+Single auxiliary <sup>6)</sup> 48:Shunt release+Auxiliary alarm <sup>6)</sup> 50:Shunt release+Under-voltage release 60:Double auxiliary(2K2B) 68:Single auxiliary+auxiliary alarm 70:Under-voltage release+Single auxiliary <sup>6)</sup> 78:Under-voltage release+auxiliary alarm <sup>6)</sup> 80:Shunt release+double auxiliary <sup>6)</sup> 90:Under-voltage release+double auxiliary <sup>6)</sup>

- means specail use for 125–800 frame
- means application for all frame
- means specail use for 1600 frame

### Example:

HDM3E125M12533XX HDM3E-125M 3P  
HDM3E400M4003350 HDM3E-400M 3P shunt release/undervoltage release AC400V  
HDM3E16XM16X33XX HDM3E-1600M 3P power module AC400V  
HDM3E16XM16X3350AP7 HDM3E-1600M 3P shunt release/power module/undervoltage release/motor mechanism AC230V

## HDM3E Molded Case Circuit Breaker(Electronic)

Product Features  
Standard:IEC/EN 60947-2



		P	B		
H	J	L	M	N	
Accessory voltage		Operation Type	Motor Mechanism	Installation Type	Temperature
Code	MX Power module	MN	Defult	Motor Mechanism/ Closing release voltage	Defult
↓	↓	↓	↓	↓	↓
Default	AC400V	AC400V	Default:manual operate	Default: -/	Defult: 40℃
A	AC230V	AC230V	P: motor mechanism	4:DC24V	B:Fixed rear T: 50℃
B	DC24V	-/	Z: ratarion manual operate <sup>5)</sup>	7:AC230V	F:Plug-in front <sup>6)</sup>
D	AC400V	AC230V		0:AC400V	R:Plug-in rear <sup>7)</sup>
E	DC24V	AC230V		C:DC110V	D:Draw-out <sup>3)</sup>
F	AC230V	AC400V		F:DC220V	
H	DC24V	AC400V			
I	DC110V	-/			
J	DC220V	-/			
K	DC110V	AC230V			
L	DC110V	AC400V			
M	DC220V	AC230V			
N	DC220V	AC400V			

### Remark:

- 1) Can choose the product reference according to above table.
- 2) 1600 AF standard offer:power module,default voltage:400V; Auxiliary contact 2open2close; Alarm contact; 3E-1600 controller; Interphase barriers 3) 125-800 AF inter accessory is standard offer with wiring(length 600mm) except undervoltage release(with terminal), if need other length or with terminal, please remark.
- 4) General product offer: interphase barriers, installation screw.
- 5) There is no withdrawable connection product of 125/250 frame, and 400/630 frame don't have plug-in front connection product.
- 6) The default horizontal outlet bar is equipped for plug-in front connection product.
- 7) Please derating to 500A when choose plug-in rear connection and withdrawable connection of 630 frame, and must adjust the max setting current Ir=500A.



## HDM3E Molded Case Circuit Breaker(Electronic)

Product selection  
Standard:IEC/EN 60947-2



### Product Features

#### Standard

- IEC 60947-1
- IEC 60947-2

#### Using Environment

Pollution degree: Class III  
IEC 60947-1 and IEC 60664-1 standard defined environment(industry environment)  
Rated working voltage to the ground is 600V, available for environment IV(power inlet line)

#### Wet and heat resistance

Dry cold,Dry heat andWet heat

#### Environment temperature

- Operating temperature: -5 degree~50 degree, average temperature don't exceed 35 degree in 24h. (Note: when you need to use this product in -35~-5 C and +50~+70 C , please refer to derating temperature table)
- Storage temperature:-40 C ~70 C

#### Altitude

- Normal installtion site do not exceed 2000m
- If altitude exceeds 2000m,must consider change factors of dielectric strength and air temperature drop. (Suggest breaking capacity derating 25%, rated impulse withstand voltage derating(12 kV reduce to 8kV, 8kV to 6kV); Rated insulation voltage derating(1000V reduce to 800V, 800V reduce to 690V)

#### Humidity

Normal operation conditions:

- If ambient air temperature is +40 ,the relative atmosphere humidity do not exceed 50%.
- The product can be used at high relative humidit if the temperature is lower.
- The wettest month of average relative humidity is 90%.
- The condensation impact on the product surface shall be considered.

#### Reliable contact indicate with isolating function

HDM3E series complies with the isolation defined in IEC 60947-2

- The isolated location show O(OFF)
- The operating handle can indicate "OFF"; when the contacts are really opened.
- Rotate handle and motor mechanism can not change the reliability of contact indicate system.Through testing,the isolating function must safe and reliable.

#### Protection class

- Circuit breaker body: IP 20
- Circuit breaker installed in switch cabint:  
With toggle handle: IP 40  
With motor mechanism: IP 40



## HDM3E Molded Case Circuit Breaker(Electronic)

Product Features  
Standard:IEC/EN 60947-2



### Nameplate Description

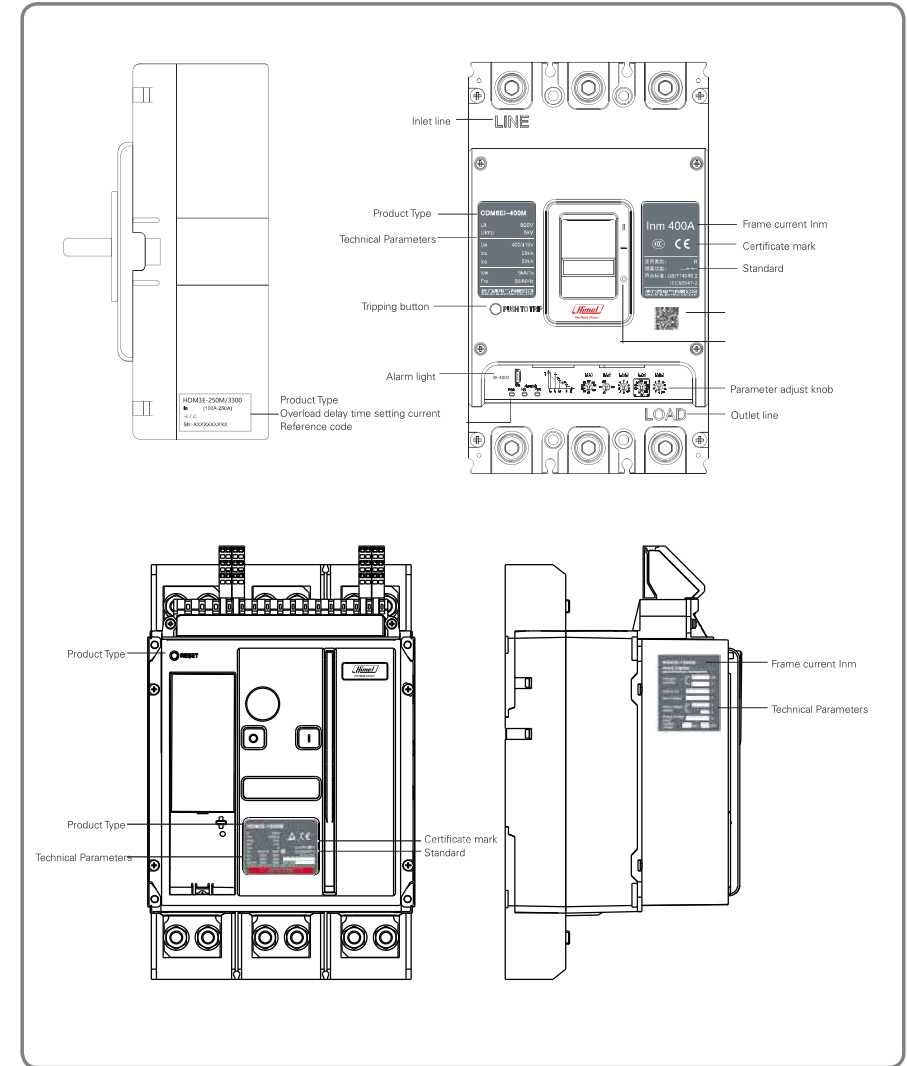



## HDM3E Molded Case Circuit Breaker(Electronic)

Product selection  
Standard:IEC/EN 60947-2



### Technical parameters

		HDM3E-125	HDM3E-250
Rated Voltage Ue (V)		400/415	400/415
Rated Insulation Voltage Ui (V)		800	800
Rated Impulse withstand Voltage Uimp (V)		8000	8000
Rated Frequency (HZ)		50	50
Frame Current(A)		125	250
Pole(3/4P)		3/4	3/4
Use Category		A	A
Breaking capacity	Breaking Class	M	M
	Icu (kA) AC 400/415V	50	50
	Ics (kA) AC 400/415V	50	50
	Icw (kA)	2.5 (1s)	2.5 (1s)
Mechanical life	With maintenance	10000	10000
	Without maintenance	7000	70000
Electrical life	AC 400/415V	1000	1000
Protection type	Power Distribution Protection		
	Motor Protection		
Tripping	Electronic tripping protection method	LSI	LSI
	Fixed front connection		
Wiring mode	Fixed rear connection		(screw type)
	Plug-in front connection		
	Plug-in rear connection(horizontal)		
	Withdrawable <sup>2)</sup>	-	-
Product accessories	Under-Voltage release		
	Shunt release		
	Alarm contact		
	Auxiliary contacts(1 open 1 close)		
	Auxiliary contacts(2 open 2 close)		
	AC/DC motor mechanism		
	Round direct manually handle		
	Square direct manually handle		
	Round extended manually handle		
	Square extended manually handle		
	Interphase barriers		
Self-installation for Accessories			
Isolating Function			
Certificate		TUV/Ce	TUV/Ce

Notes: 1) Product rear horizontal connection can be revised to Vertical connection, refer to P40.  
2) Product rear horizontal connection can be revised to fixed front connection and rear Vertical connection, refer to P43.

## HDM3E Molded Case Circuit Breaker(Electronic)

Product Features  
Standard:IEC/EN 60947-2



	HDM3E-400	HDM3E-630	HDM3E-800	HDM3E-1600	
Rated Voltage Ue (V)	400/415	400/415	400/415	400/415	
Rated Insulation Voltage Ui (V)	800	800	1000	1000	
Rated Impulse withstand Voltage Uimp (V)	8000	8000	12000	12000	
Rated Frequency (HZ)	50	50	50	50	
Frame Current(A)	400	630	800	1600	
Pole(3/4P)	3/4	3/4	3/4	3/4	
Use Category	B	B	B	B	
Breaking capacity	Breaking Class	M	M	M	
	Icu (kA) AC 400/415V	50	50	50	
	Ics (kA) AC 400/415V	50	50	50	
	Icw (kA)	5 (1s)	8 (1s)	10 (1s)	42 (1s)
Mechanical life	With maintenance	7000	7000	5000	1500
	Without maintenance	4000	4000	2500	500
Electrical life	1000	1000	500	500	
Protection type	Power Distribution Protection				
	Motor Protection				
Tripping	Electronic tripping protection method	LSI	LSI	LSI	LSI/G
	Fixed front connection				
Wiring mode	Fixed rear connection		(Horizontal) <sup>1)</sup>	(Horizontal) <sup>1)</sup>	-
	Plug-in front connection	-	-	-	-
	Plug-in rear connection(horizontal)	(Horizontal) <sup>2)</sup>	(Horizontal) <sup>2)</sup>	(Horizontal) <sup>2)</sup>	-
	Withdrawable <sup>2)</sup>				-
Product accessories	Under-Voltage release				
	Shunt release				
	Alarm contact				
	Auxiliary contacts(1 open 1 close)				
	Auxiliary contacts(2 open 2 close)				
	AC/DC motor mechanism				
	Round direct manually handle				
	Square direct manually handle				
	Round extended manually handle				-
	Square extended manually handle				-
	Interphase barriers				-
Self-installation for Accessories					-
Isolating Function					
Certificate		TUV/Ce	TUV/Ce	TUV/Ce	TUV/Ce

# HDM3E Molded Case Circuit Breaker(Electronic)

Controller Parameters(125-800AF)  
Standard:IEC/EN 60947-2



## HDM3E series controller function and features

### HDM3E-125~800

#### 3P controller



#### 4P controller



#### Controller Description

$I_n$  :Overload long delay setting current  
Isd :Short-circuit short delay setting current  
Ii :Short-circuit instantaneous setting current  
Ready :Run light  
> 90% $I_n$  :pre-alarm light

$t_n$  :Overload long delay setting time  
tsd :Short-circuit short delay setting time  
 $I_{RN}$  :Short-circuit short delay setting time  
Alarm :Alarm light  
> 105% $I_n$  :Overload alarm light

LSI three section protection curve

### 1) Overload long delay setting current $I_n$

Adjust I R knob, can select the different current value of HDM3E, to satisfy the rated operating current requirement of different electrical wiring.

Following sketch is the adjust knob:  $I_n$

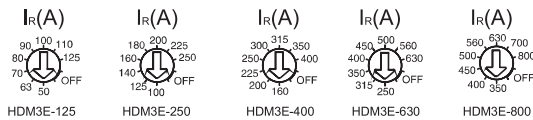

Product Type	Overload long delay current, protection feature setting value, $I_n$ (A)	Remark
HDM3E-125	50,63,70,80,90,100,110,125	OFF means close overload long delay protection
HDM3E-250	100,125,140,160,180,200,225,250	OFF means close overload long delay protection
HDM3E-400	160,200,225,250,300,315,350,400	OFF means close overload long delay protection
HDM3E-630	250,315,350,400,450,500,560,630	OFF means close overload long delay protection
HDM3E-800	350,400,450,500,560,630,700,800	OFF means close overload long delay protection

# HDM3E Molded Case Circuit Breaker(Electronic)

Controller Parameters(125-800AF)  
Standard:IEC/EN 60947-2



### 2) Overload long delay setting time $t_n$



#### $t_R$ Action time @ $2I_n$

The following table is action value corresponding for different overload long delay time when the fault current is  $1.5I_n$ ,  $2I_n$ ,  $6I_n$

Actual Current	Action time to different knob $t_n$ (s), accuracy $\pm 10\%$ , $t = (2I_n / I)^2 \times t_n$				
	12	60	80	100	150
$1.5I_n$	21.3	106.7	142.2	177.8	266.7
$2I_n$	12	60	80	100	150
$6I_n$	1.33	6.67	8.89	11.11	16.67

As example of HDM3E-400 product, how to set the overload long delay setting current and time. If select  $I_n$  300,  $t_n$  is 60.

When overload current is  $1.5I_n$ (450A), the range of overload action time is  $106.7 \pm 10.67$ s.

When overload current is  $2I_n$ (600A), the range of overload action time is  $60 \pm 6$ s.

.When overload current is  $6I_n$ (1800A), the range of overload action time is  $6.67 \pm 0.667$ s.

It is the same theory for the other section knob value.

### 3) Short-circuit short delay setting current $I_{sd}$

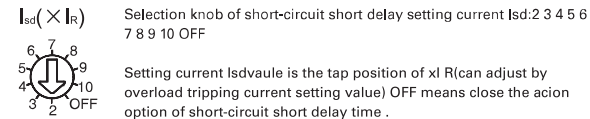

### 4) Short-circuit short delay setting time $t_{sd}$

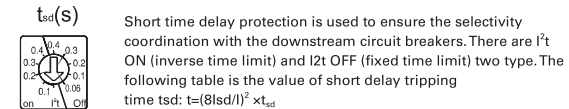

## HDM3E Molded Case Circuit Breaker(Electronic)

Controller Parameters(125-800AF)  
Standard:IEC/EN 60947-2



### 5) Short-circuit Instantaneous setting current $I_i$ ( $\times I_{nm}$ )

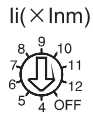

Short-circuit Instantaneous setting current $I_i$ ( $\times I_{nm}$ )	HDM3E-125/250 /400/630/800	(4,5,6,7,8,9,10,11,12,OFF) $\times I_{nm}$
---	----------------------------	--

### 6) Neutral phase setting protection $I_{RN}(\times I_R / I_{nm})$



Setting current  $I_{RN}$  value selected knob is  $\times I_R / I_{nm}$ . Neutral phase protection is special for 4 poles circuit breakers. There are three type:

- OFF: Close neutral phase protection function, used for power distribution system without neutral protection situation
- N/2: Used for neutral phase wiring conductor cross-section equal to half of phase line of power distribution system long time delay, short time delay are also equal to the 1/2 of setting value of phase line protection in this status
- N: Used for neutral phase wiring conductor cross-section equal to phase line of power distribution system long time delay, short time delay instantaneous setting value are also equal to setting value of phase line protection in this status.

Note: When  $I_{RN}$  is OFF, controller will automatically use the basic reference( $I_{nm}$ ) current as the neutral phase protection

### 7) Controller working status indicate

Following table is status of Run indicate light(Ready), Alarm indicate light(Alarm):

Run status	Ready		Alarm		Remark
	Green	Yellow	Yellow	Red	
Normal	Blink	Extinguish	Extinguish	Extinguish	$I < 0.9I_R$
Pre-alarm	Blink	Blink	Extinguish	Extinguish	$0.9I_R \leq I \leq I_R$
Tripping	Extinguish	Extinguish	Extinguish	Extinguish	$1.05I_R < I$

Note:

- 1,  $I$  is current of main circuit,  $I_R$  is overload long time delay setting current value.
- 2, When yellow light blink, that means intelligent controller had worker on overload long time delay, setting parameters on the controller board is unavailable in this process.

## HDM3E Molded Case Circuit Breaker(Electronic)

Controller Parameters(125-1600AF)  
Standard:IEC/EN 60947-2



### 3E Controller Function and Characteristics

#### 3E-1600( Basic type )

##### Indicate and button description

- |   |  |
|---|--|
| 1 Alarm indicate light                                | 9 Short time delay Isd                 |
| 2 Long time delay tripping indicate                   | 10 Short time delay tripping delay tsd |
| 3 Short time delay or Instantaneous tripping indicate | 11 Earthing fault tripping Ig          |
| 4 Earthing tripping indicate                          | 12 Earthing fault tripping delay tg    |
| 5 High level protection                               | 13 Lock position                       |
| 6 Reset button  | 14 Testing button                      |
| 7 Long time delay current setting $I_R$               | 15 Instantaneous tripping current      |
| 8 Long time delay tripping delay $t_R$                | 16 Testing connection port             |

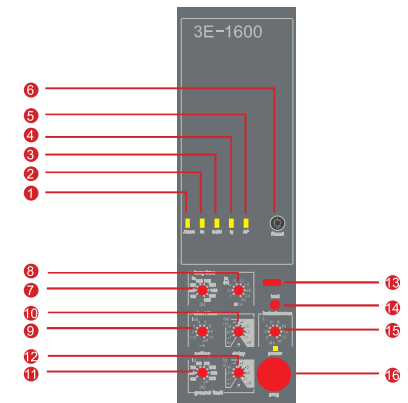

#### 3E-T1600(Communication Type)

##### Indicate and button description

- |   |                                     |
|---|-------------------------------------|
| 1 Alarm indicate light                                | 11 Earthing fault tripping Ig       |
| 2 Long time delay tripping indicate                   | 12 Earthing fault tripping delay tg |
| 3 Short time delay or Instantaneous tripping indicate | 13 Lock position                    |
| 4 Earthing tripping indicate                          | 14 Testing button                   |
| 5 High level protection                               | 15 Instantaneous tripping current   |
| 6 Reset button  | 16 Testing connection port          |
| 7 Long time delay current setting $I_R$               | 17 Setting button/Switch button     |
| 8 Long time delay tripping delay $t_R$                | 18 PgDn or PgUp button              |
| 9 Short time delay Isd                                | 19 Confirmation button              |
| 10 Short time delay tripping delay tsd                |                                     |

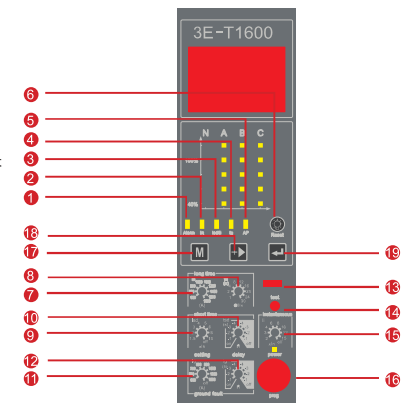

Note: 7 8 9 10 11 12 15 only stall indicate, don't adjust.



## HDM3E Molded Case Circuit Breaker(Electronic)

Controller Parameters(1600AF)  
Standard:IEC/EN 60947-2



### Function Description

3E-1600



3E-T1600

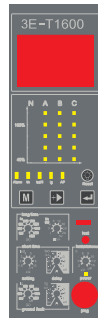

Protection Function	3E-1600	3E-T1600
Long-time delay protection $I_R$	Long-time delay protection $I_R$	Long-time delay protection $I_R$
Short-time delay protection $I_{sd}$	Short-time delay protection $I_{sd}$	Short-time delay protection $I_{sd}$
Instantaneous protection $I_i$	Instantaneous protection $I_i$	Instantaneous protection $I_i$
Earthing protection $I_g$	Earthing protection $I_g$	Earthing protection $I_g$
MCR protection	MCR protection	MCR protection
HSISC protection	HSISC protection	HSISC protection
		Current unbalance
		Maximum required current
		Earthing alarm
Measure Function		
		Current measure
		Voltage measure
		Power measure
		Frequency measure
		Electric energy measure
Miscellaneous Function		
Pre-alarm	Pre-alarm	Pre-alarm
Self-diagnosis function	Self-diagnosis function	Self-diagnosis function
Fault history record	Fault history record	Fault history record
Measure function	Measure function	Measure function
		Displacement record
		Alarm record
		Clock
Display Function		LCD Display <sup>1)</sup>
Communication Function		Modbus

1) LCD will freeze when environment under minus 5°C, it will cause undisplay, but it don't affect the protection function and normal operating of circuit breakers.

## HDM3E Molded Case Circuit Breaker(Electronic)

Controller Parameters(125-800AF)  
Standard:IEC/EN 60947-2



### Intelligent Controller Protection Characteristics

Intelligent controller protection characteristics have inverse time limit and fixed time limit. When fault current exceed the setting value of inverse time limit, controller will work on the delay time protection according to fixed time limit setting. Inverse time limit curve conform to characteristics curve  $I^2 t$

#### 1) Overload long time delay protection characteristics $I_R$

Overload long time delay protection action threshold value

$< 1.05 I_R > 2h$  inaction

$\geq 1.2 I_R$ ; action delay

$I_R$  current setting range:630A,800A,900A,1000A,1100A,1250A,1400A,1500A,1600A

Inverse time limit action characteristics	$I^2 t = (6/N)^2 * I_R$								
Setting current	Action time s								
$1.5 I_R$	16s	32s	64s	128s	192s	256s	320s	384s	480s
$2 I_R$	9s	18s	36s	72s	108s	144s	180s	216s	270s
$6 I_R$	1s	2s	4s	8s	12s	16s	20s	24s	30s

Notes: N---- Fault current divide by setting current  $I_R$

t----Fault action delay time

$t_R$  ----Long time delay setting value

Action time permissible error $\pm 10\%$

#### 2) Short-circuit short time delay protection characteristics $I_{sd}$

Short-circuit short time delay protection action threshold value

$< 0.9 I_{sd}$  inaction

$\geq 1.1 I_{sd}$ ; action delay

$I_{sd}$  current setting range:1.5  $I_R$ , 2  $I_R$ , 3  $I_R$ , 4  $I_R$ , 5  $I_R$ , 6  $I_R$ , 8  $I_R$ , 10  $I_R$ , OFF

Setting current	Action time					
$I_{sd} < 1.1 I_{sd}$	Inverse time limit	Action character	$I^2 t = (8 I_{sd} / t)^2 t_{sd}$			
			Delay time s	0.1, 0.2, 0.3, 0.4		
$I \geq 1.1 I_{sd}$	Fixed time limit, returned time is minimum value	Setting time s	0.1	0.2	0.3	0.4
		Min s	0.08	0.14	0.23	0.35
		Max s	0.14	0.2	0.32	0.5

Notes:  $I_{sd}$  ---- Short time delay current setting value

I ---- Fault current value

$I_R$  ---- Long delay time current setting value

t ---- Fault action delay time

$t_{sd}$  ---- Short time delay inverse time limit setting value

Action time permissible error  $\pm 20\%$

(The off of time means I2 t is inverse time limit closed, this state is fixed inverse limit; use current knob is off, that means short time delay protection function is closed.)

#### 3) Instantaneous Protection Characteristics $I_i$

Short-circuit instantaneous protection action threshold value

$< 0.85 I_i$  inaction

$> 1.15 I_i$  action

Instantaneous action current setting value 2 $I_n$ , 3 $I_n$ , 4 $I_n$ , 6 $I_n$ , 8 $I_n$ , 10 $I_n$ , 12 $I_n$ , 15 $I_n$ , OFF

Note: Action time permissible error  $\leq 50ms$ .

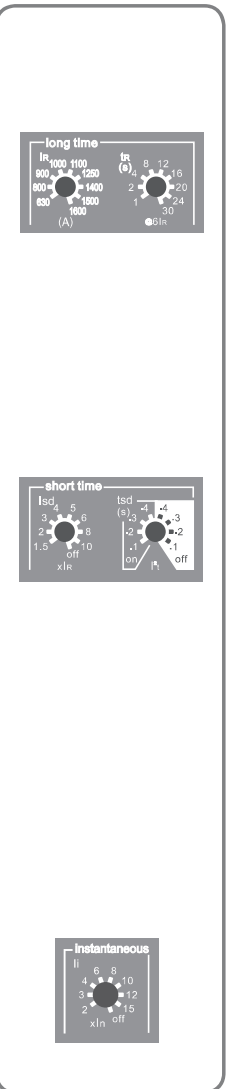

## HDM3E Molded Case Circuit Breaker(Electronic)

Controller Parameters(1600AF)  
Standard:IEC/EN 60947-2



### 4) Earthing Fault Protection Action Characteristics I<sub>g</sub>

Earthing fault protection action threshold value

< 0.9 I<sub>g</sub>; inaction

≥ 1.1 I<sub>g</sub>; action delay

I<sub>g</sub> current setting range:500A, 600A, 700A, 800A, 900A, 1000A, 1100A, 1200A, OFF

tg(s)	Inverse time limit	Action Charater				
		$t = \frac{(I_f)^2}{I^2} \times t_g$				
Fixed time limit, returned time is minimum value	Settingtime (s)	0.1	0.2	0.3	0.4	
	Settingtime (s)	0.1	0.2	0.3	0.4	
	Min (s)	0.08	0.14	0.23	0.35	
	Max (s)	0.14	0.2	0.32	0.5	

Notes: IJ Earthing protection setting value IJ =1200A

I Fault current value

T Fault action delay time

tg Earthing inverse time limit setting value

Inverse time limit action permissiable error ± 20%

(The off means is inverse time limit closed, this state is fixed time limit. Use current knob is off, that means earthing protection function is closed.)

### 5) Intelligent controller setting value

Tripping curve	Long time delay		Short time delay		Instantaneous	Earthing fault		Thermal momory
	I <sub>R</sub>	t <sub>R</sub>	I <sub>sd</sub>	t <sub>s</sub>	I <sub>i</sub>	I <sub>g</sub>	t <sub>g</sub>	
I <sub>Δ</sub> t	1600A	30s	6In	0.2s	10In	1100A	0.4s	20min

## HDM3E Molded Case Circuit Breaker(Electronic)

Controller Parameters(125-1600AF)  
Standard:IEC/EN 60947-2



### Secondary wiring diagram

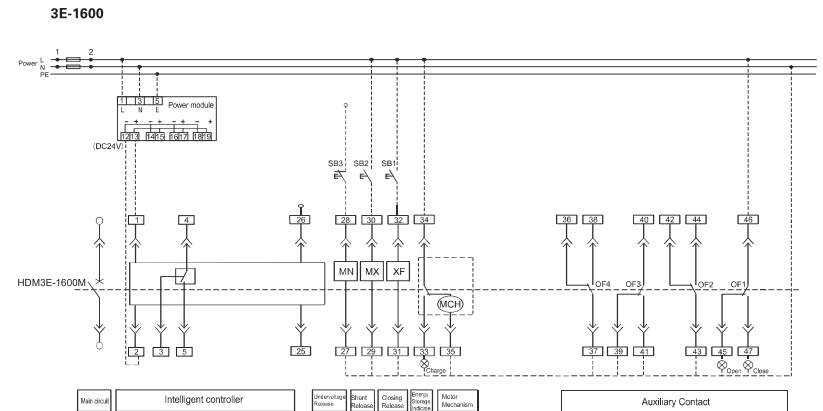

Controller Introduction:

Power: Power supply

1#,2# is auxiliary power DC24V , 1# is connect to positive terminal, and 2# is connect to negative terminal.

SWT: Fault tripping contact outlet(alarm contact)

3#,4#,5# are a set of transfer contact, and 4# is the common terminal, AC 400V,5A.

Note 1: 27#, 28# is under-voltage release terminal, connect from main circuit.

Note 2: controller must connect power supply, when voltage power is AC220/230V, use iAPU331 power module; when power is AC380/400V, use iAPU332 power module, when power is DC220/110V, use iAPU332D power module.

Note 3: HDM3E-1600M standard equipped with 2 open 2 close contact.

Note 4: MN, MX, XF,MCH are also optional accessories.

Note 5: Terminal 35# can not only be connected to power supply directly, achieve pre-storage energy automatically, but also can connect to the power supply by tandem connection with normal open button (achieve pre-storage energy manually). The dotted line part need connect by user.

Button by users:

SB1—closing button

SB2—opening button

SB3—emergency cut-off button

Components:

MN— Under-voltage release

MX— Shunt release

XF— Closing release

MCH— Motor mechanism

OF1-OF4—Auxiliary contacts

# HDM3E Molded Case Circuit Breaker(Electronic)

Controller Parameters(1600AF)  
Standard:IEC/EN 60947-2



## Secondary wiring diagram

3E-T1600

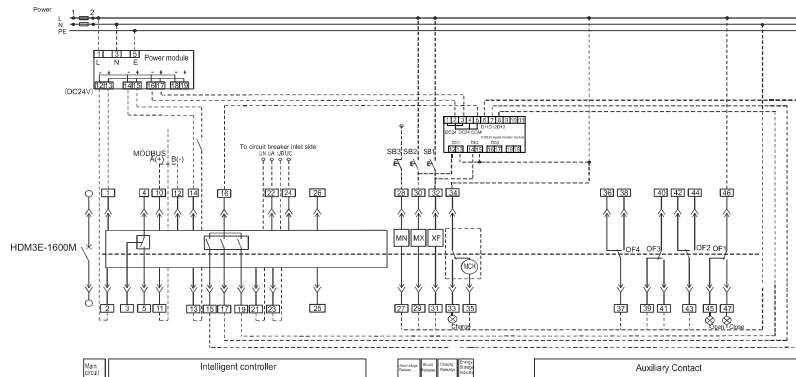

### Controller Introduction:

#### UM: Voltage measure signal input

21#, 22#, 23#, 24# is the input of N,A,B,C phase voltage.

#### ZSI: switch value in common, DI, DO function is defined by customer

13#, 14# is input of DC24V, 13# is connect to positive terminal, and 14# is connect to negative terminal.

15#, 16# is remote open, 16#, 17# is remote closing, 16#, 19# is general DO, and 16# is common terminal.

#### Power: Power supply input

1#, 2# is auxiliary power DC24V, 1# is connect to positive terminal, and 2# is connect to negative terminal.

#### SWT: Fault tripping contact outlet(alarm contact)

3#, 4#, 5# are a set of transfer contact, and 4# is the common terminal, AC 400V, 5A.

#### Com: Communication output

10#, 11# is communication connection, 12# is communication ground

#### Button by users:

SB1—closing button

SB2—opening button

SB3—emergency cut-off button

#### Components:

MN— Under-voltage release

MX— Shunt release

XF— Closing release

MCH— Motor mechanism

OF1—OF4—Auxiliary contacts

Note 1: 27#, 28# is under-voltage release terminal, connect from main circuit.

Note 2: controller must connect power supply, when voltage power is AC220/230V, use iAPU331 power module; when power is AC380/400V, use iAPU332 power module, when power is DC220/110V, use iAPU332D power module.

Note 3: When controller by remote, need to install signal transfer module(ICIO333, contact capacity is AC240V, 10A); the signal transfer module is equipped standard for four communication type product. It only can have three communication function (remote measure, remote test, remote communication) without signal transfer module

Note 4: HDM3E-1600M standard equipped with 2 open 2 close contact.

Note 5: Modbus-RTU is communication protocol, input terminal connect to 10#, 11#(cCom), output connect to bus of related protocol

Note 6: Terminal 35# can not only be connected to power supply directly, achieve pre-storage energy automatically, but also can connect to the power supply by tandem connection with normal open button (achieve pre-storage energy manually). The dotted line part need connect by user.

# HDM3E Molded Case Circuit Breaker(Electronic)

Product selection  
Standard:IEC/EN 60947-2



## Accessories Selection

HDM3E	Frame	Accessories
	125	H1
	125A	AL1: Alarm contact(with wire)
	250A	AL2: Alarm contact(with terminal)
	400A	MX1: Shunt release(with wire)
	630A	MX2: Shunt release(with terminal)
	800A	OF11K1B: Auxiliary contact 1K1B(with wire)
	<b>1600A</b>	OF21K1B: Auxiliary contact 1K1B(with terminal)
		OF12K2B: Auxiliary contact 2K2B(with wire)
		OF22K2B: Auxiliary contact 2K2B(with terminal)
		MN: Undervoltage release
		C3:3P Expanding terminal(6pcs)
		C4:4P Expanding terminal(8pcs)
		H1: Round direct handle
		H2: Square direct handle
		IB3:3P Interphase barriers(6pcs)
		IB4:4P Interphase barriers(8pcs)
		HL1 :Round extended rotation handle
		HL2 :Square extended rotation handle
		D: AC/DC motor mechanism
		M3EMKAC230DC24: Input AC230V output DC24V
		M3EMKAC400DC24: Input AC400V output DC24V
		M3EMKDC110DC24: Input DC110V output DC24V
		M3EMKDC220DC24: Input DC220V output DC24V

means application for 125–800 frame

means application for all frame

means application for 1600 frame



## HDM3E Molded Case Circuit Breaker(Electronic)

Installation Dimension  
Standard:IEC/EN 60947-2



### Product appearance and installation dimension of 125A-800A

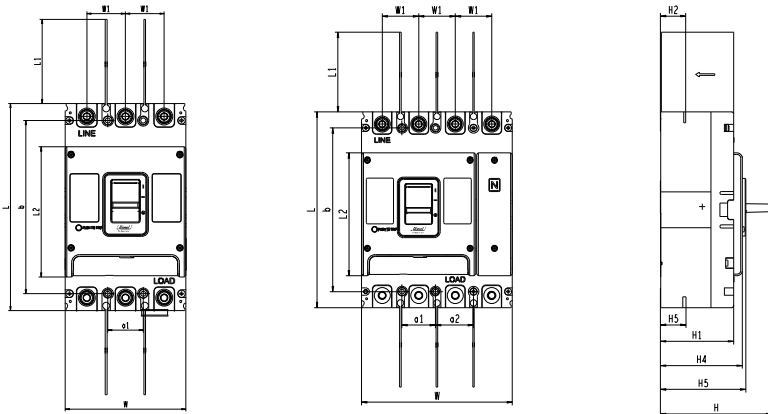

Unit: mm

Product	Pole	Appearance dimension										Installation dimension			
		L	L1	L2	W	W1	H	H1	H2	H3	H4	H5	a1	a2	b
HDM3E-125	3	165	80	102.5	107	35	112.5	86	21.5	23	94	95.5	35	35	126
	142														
HDM3E-250	3	165	80	102.5	107	35	112.5	86	23	23	94	95.5	35	35	126
	142														
HDM3E-400	3	257	104.5	161.5	150	48	145.9	96.2	36.5	37	107.5	112.2	44	-	215
	198														
HDM3E-630	3	257	104.5	161.5	150	48	145.9	96.2	38.5	39.5	107.5	112.2	44	-	215
	198														
HDM3E-800	3	280	104.5	170	210	70	154	103	40.5	47	116	121	70	70	243
	280														

## HDM3E Molded Case Circuit Breaker(Electronic)

Installation Dimension  
Standard:IEC/EN 60947-2



### Safety clearance(125A-800A MCCB)

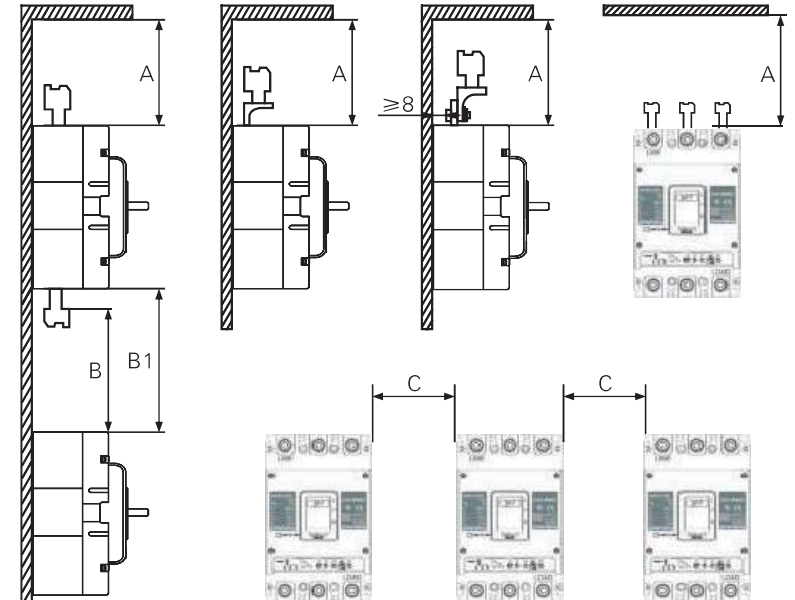

Product	A (mm)	B (mm)	B1 (mm)	C (mm)
HDM3E-125/250	60	60	Length of bare cable +B	30
HDM3E-400/630	110	110		70
HDM3E-800	110	110		70

Note:No matter there is product with accessory or not,safety clearance must meet requirement of C.

## HDM3E Molded Case Circuit Breaker(Electronic)

Installation Dimension  
Standard:IEC/EN 60947-2



### Fixed front installation hole dimensions(125-800A MCCB)

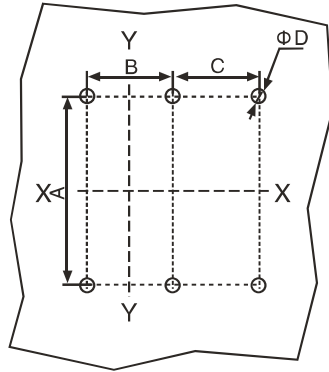

Note:X-X and Y-Y is the center of the three-pole breaker.

Unit: mm

Product	Pole	A	B	C	ΦD
HDM3E-125	3	126	35	-	5.5
	4			35	
HDM3E-250	3	126	35	-	5.5
	4			35	
HDM3E-400	3	215	44	-	6.5
	4			-	
HDM3E-630	3	215	44	-	6.5
	4			-	
HDM3E-800	3	243	70	-	7.5
	4			70	

## HDM3E Molded Case Circuit Breaker(Electronic)

Installation Dimension  
Standard:IEC/EN 60947-2



### Safety clearance(125A-800A MCCB)

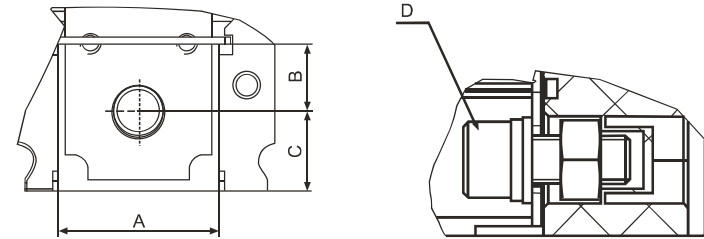

Unit: mm

Product	A	B	C	D
HDM3E-125	25.5	12	10	M8x20
HDM3E-250	25.5	12	10	M8x20
HDM3E-400	32	13	16	M10×25
HDM3E-630	32	13	16	M10×35
HDM3E-800	45.5	16.8	18.5	M12×35

## HDM3E Molded Case Circuit Breaker(Electronic)

Installation Dimension  
Standard:IEC/EN 60947-2



### Fixed and plug-in rear plate hole dimension

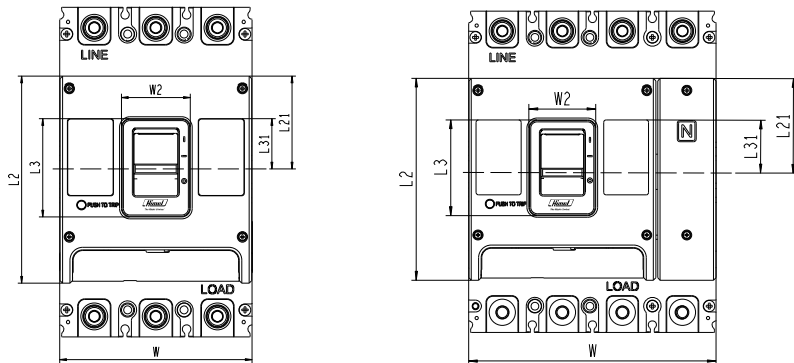

Unit:mm

Product	Pole	Cover and handle reveal			Only handle reveal		
		W	L2	L21	W2	L3	L31
HDM3E-125	3	107	102.5	51	26	50.5	26.5
	4	142					
HDM3E-250	3	107	102.5	51	26	50.5	26.5
	4	142					
HDM3E-400	3	150	161.5	75	52.5	75.5	41
	4	198					
HDM3E-630	3	150	161.5	75	52.5	75.5	41
	4	198					
HDM3E-800	3	210	170	67.5	55	85	42.5
	4	280					

## HDM3E Molded Case Circuit Breaker(Electronic)

Installation Dimension  
Standard:IEC/EN 60947-2



### Product connection

#### 1 Notice

- 1.Wiring connection must be implemented by qualified persons
- 2.wiring connection after ensuring incoming power is cut off
- 3.wiring connection after MCCB installation
- 4.MCCB wire connection must be correct,connecting "LINE"to power supply,and"LOAD" to equipments, upside down is forbidden.

#### 2 Choosing standrand wire

The size of wire for different frame of product

Table1:

Product	The size of wire (mm <sup>2</sup> )	Quantity
HDM3E-125	50	1
HDM3E-250	120	1
HDM3E-400	240	1
HDM3E-630	185	2
HDM3E-800	240	2

Note:If product connect with Busbar,it will need to use with extension terminal.

#### 3 Choosing ring tongue connection terminal and connection terminal

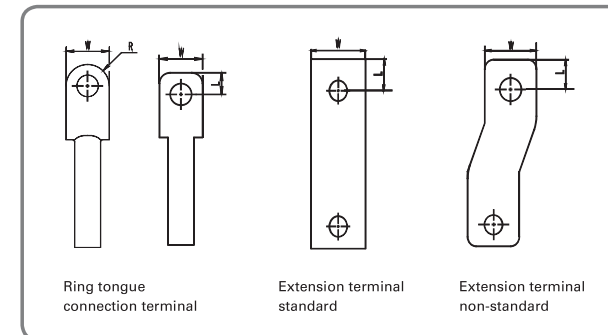



## HDM3E Molded Case Circuit Breaker(Electronic)

Installation Dimension  
Standard:IEC/EN 60947-2



Product	Ring tongue connection terminal		
	W	R (L)	part number of ring tongue connection terminal
HDM3E-125	≤ 25	≤ 12	35mm <sup>2</sup> : DT035SGD/DT035SED/DTG035SHD/DTL035MGD/SC35M8ZXD/SC35M10ZXD 50mm <sup>2</sup> : DT050SGD/DT050SED/DTG050SHD/DTL050MGD/SC50M8ZXD/SC50M10ZXD/SC50M12ZXD OT : OT100ASD/OT150ASD
HDM3E-250			70mm <sup>2</sup> : DT070SED/DTG070SHD/SC70M10ZXD/SC70M12ZXD 95mm <sup>2</sup> : SC95M10ZXD/SC95M13ZXD OT : OT250ASD/OT300ASD
HDM3E-400	≤ 32	≤ 13	120mm <sup>2</sup> : DT120SGD/DT120SED/DTG120SHD/DTL120MGD/DHADT120M13W28FT 150mm <sup>2</sup> : DT150SED/DHADT150M13W30FT 185mm <sup>2</sup> : DHADT185M13W31FT OT : OT400ASD
HDM3E-630			240mm <sup>2</sup> : DT240SGD/DT240SED/DHADT240M14W398FT
HDM3E-800			

### Note

- The type and part number of terminals in the table are Himel's type and part number
- The size of cable matched with terminal must be bigger than the size in the table, standard type is recommended

### 4

The screw must be tightened, torque shall be bigger than the table below. Interphase barriers must be installed as picture below. In case of short circuit between the phase, insulated end of cable is necessary.

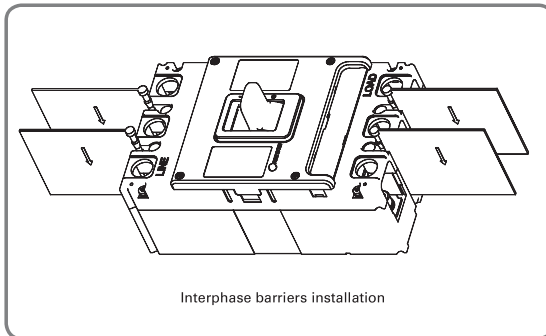

Product	Screw for connection	Torque(N.m)
CDM6EI-125/250	M8 × 20mm	9.5 -10.5
CDM6EI-400/630	M10 × 25mm	19.5-20.5
CDM6EI-800	M12 × 35mm	29.5-30.5

## HDM3E Molded Case Circuit Breaker(Electronic)

Installation Dimension  
Standard:IEC/EN 60947-2



### Fixed installation of 3 and 4 poles of 1600A

#### Fixed rear installation dimensions

Unit:mm

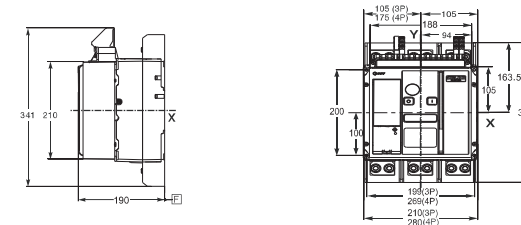

#### Vertical installation

Unit:mm

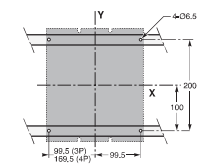
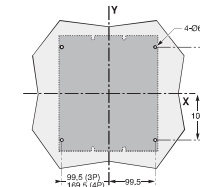
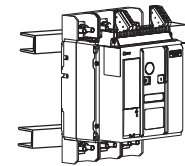
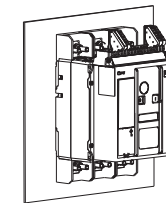
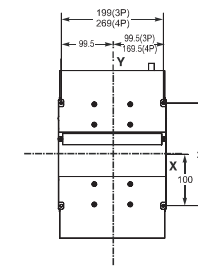

Note: X and Y are plane of symmetry of 3 pole breaker Z is back plane of breaker.

#### With doorframe: Holes dimension on door

#### Without doorframe: Holes dimension on door

Unit:mm

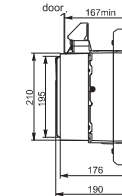
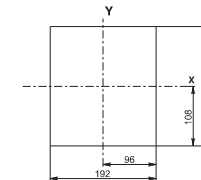
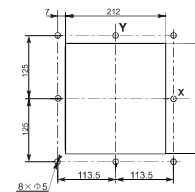

## HDM3E Molded Case Circuit Breaker(Electronic)

Installation Dimension  
Standard:IEC/EN 60947-2



### Fixed rear installation dimension 1600A

Safety distance

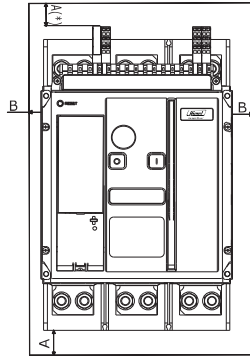

	Insulation part	Metal part	Charged part
A	0	120	180
B	0	10	60

注: X and Y are front plane symmetric axis.

(\*) 50mm safety distance for removing arcing cover, 20mm safety distance for removing terminals.

**F** : Reference point.

## HDM3E Molded Case Circuit Breaker(Electronic)

Installation Dimension  
Standard:IEC/EN 60947-2



### 1600A appearance and installation dimension

The table below based on assumption below:

- The highest temperature is 100°C on busbar
- Ti Environment temperature around breaker and connection parts
- Copper varnished wire

Note:

The date in the table below comes from test and theoretical calculation under assumption condition above.

The table below is helpful to connection part design, but need to test to be confirmed.

Front connection parts

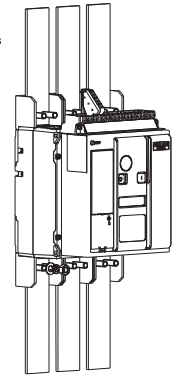

Max current	Ti:40°C the number of busbar		Ti:50°C the number of busbar		Ti:60°C the number of busbar	
	5mm Thickness	10mm Thickness	5mm Thickness	10mm Thickness	5mm Thickness	10mm Thickness
630	2b.40x5	1b.40 x 10	2b.40x5	1b.40 x 10	2b.40x5	1b.40 x 10
800	2b.50x5	1b.50 x 10	2b.50x5	1b.50 x 10	2b.50x5	1b.63 x 10
1000	3b.50x5	1b.63 x 10	3b.50x5	2b.50 X 10	3b.63x5	2b.50 x 10
1250	3b.50x5	2b.40 x 10	3b.50x5	2b.50 X 10	3b.63x5	2b.50 x 10
	2b.80x5	2b.40 x 10	2b.80x5			
1600	3b.80x5	2b.63 x 10	3b.80x5	2b.63 x 10	3b.80x5	2b.50 x 10

Note

The data in the tables above are derived from experiments and theoretical calculations, and it is not possible to substitute industrial experience or temperature rise tests for guidance only.

Product	A	B	C	screw	E	Torque range(N.M)
HDM3E-1600M	59	17.2	32.8	M10 X 40mm	25	50

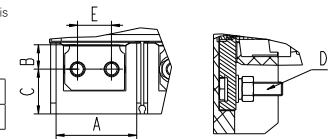

### Front connection size

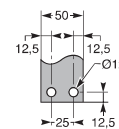

Recommended the size of busbar

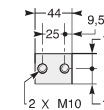

The size of top terminal

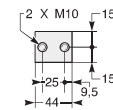

The size of bottom terminal

# HDM3E Molded Case Circuit Breaker(Electronic)

Installation Dimension  
Standard:IEC/EN 60947-2



## 1600A Fixed busbar

Front Connexion

Unit:mm

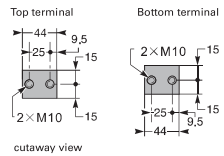
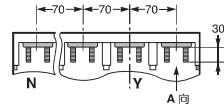
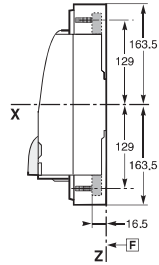
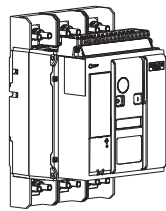

Remark:  
Recommend screw: M10,  
Torque:50 N.M.

Front connection with extension terminal

Unit:mm

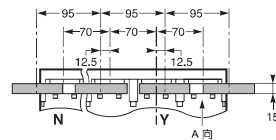
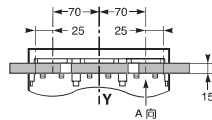
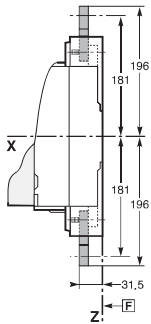
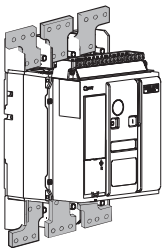

# HDM3E Molded Case Circuit Breaker(Electronic)

Installation Dimension  
Standard:IEC/EN 60947-2



## 1600A Fixed busbar

Extension terminal drawing

Unit:mm

Extension terminal for A phase or B phase of 4 pole

Extension terminal for B phase of 3 pole

Extension terminal for N phase or C phase of 4 pole

Extension terminal for A phase or C phase of 3 pole

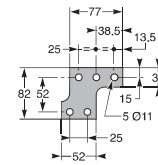
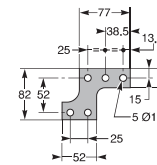
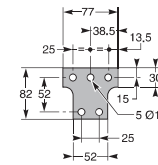
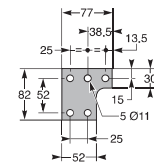

Cutaway view



## HDM3E Molded Case Circuit Breaker(Electronic)

Installation Dimension  
Standard:IEC/EN 60947-2



### 1600A Power supply module&single conversion module dimension

Supply power module can be installed on 35mm DIN rail.

Unit:mm

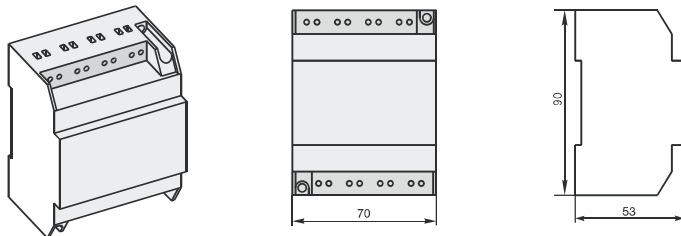

Signal conversion module can be installed on 35mm DIN rail

Unit:mm

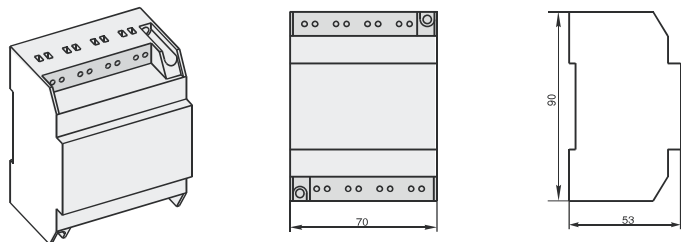

## HDM3E Molded Case Circuit Breaker(Electronic)

Accessory Installation  
Standard:IEC/EN 60947-2



### Internal accessories installation(125A-800A MCCB)

Diagram of inside accessories installation

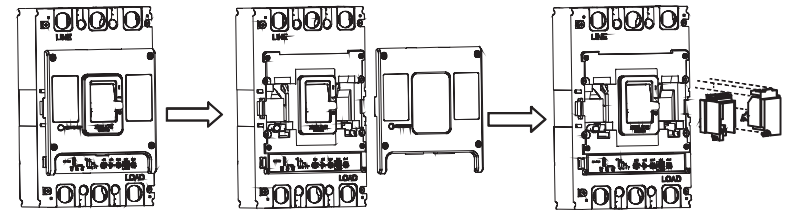

Take the top cover down, and put accessories into left and right chamber of the middle cover and compress it, and install the top cover, tighten the screws. An accessory can be installed in the left or right position, including shunt release, undervoltage release, auxiliary contact, alarm and auxiliary contact.

Internal accessory wiring diagram

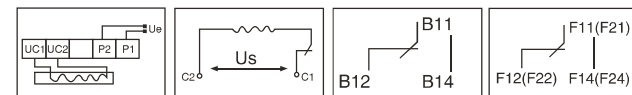

Undervoltage release

Shunt release

Alarm contact

Auxiliary contact

When rated voltage of shunt release is DC24V, the longest of copper wire is no more than data below:

Rate voltage for control power $U_s$ (DC24V)	Sectional area 1.5mm <sup>2</sup>	Sectional area 2.5mm <sup>2</sup>
100% $U_s$	150m	250m
80% $U_s$	100m	160m

If you can not match requirement the above table, the following diagram is used to design the control circuit of the shunt release:

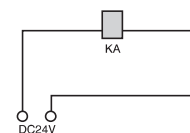

KA: DC24V relay Current capacity :1A

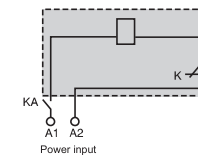

Voltage of power input  
AC50Hz 230V 400V; DC110V 220V

## HDM3E Molded Case Circuit Breaker(Electronic)

Accessory Installation  
Standard:IEC/EN 60947-2



### Internal accessories test

- 1,Shut down power supply for undervoltage release, breaker should be off, handle is on trip position
- 2,Shunt release is under reted voltage,breaker should be off,handle is on trip position
- 3,Switch on or off breaker with auxiliary contact,auxiliary contact can conversion normally singal
- 4,Switch on or trip(press red button) breaker,alarm contact can conversion normally singal

Note:The electrified time of shunt release lasts no more than 5s, otherwise shunt release will burnt out.When rated voltage of control power is DC24V,rated current of control circuit is 4.5~5.5A.

## HDM3E Molded Case Circuit Breaker(Electronic)

Accessory Installation  
Standard:IEC/EN 60947-2



### Outside accessories installation(125A-800A MCCB)

Handle operation mechanism installation drawings.

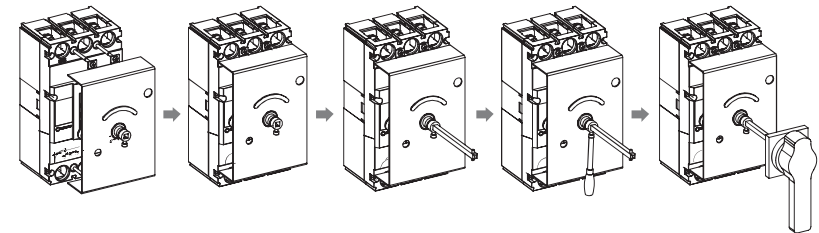

Rotary handle and installation dimension Unit: mm

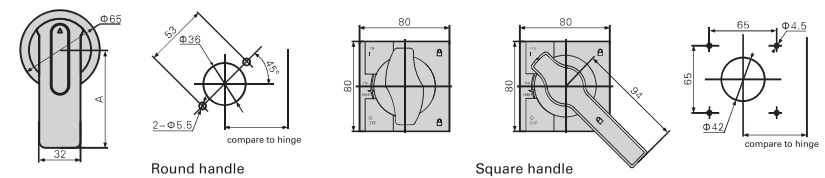

Dimension of mechanism

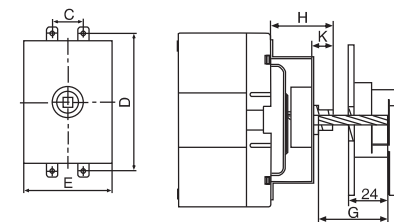

产品型号	C	D	E	H	K
CDM6E1-125/250	35	143	100	49	20
CDM6E1-400/630	44	215	140	76	20
CDM6E1-800	70	243	210	76	20

Installed rotary handle, operation should be flexible, and the handle in the horizontal, circuit breaker should be switched on, handle in the vertical position, circuit breaker should be closed.

Note

1 G means the shortest connection bar is 40mm,standard is 150mm,can be customizational.

## HDM3E Molded Case Circuit Breaker(Electronic)

Accessory Installation  
Standard:IEC/EN 60947-2



### Motor operating mechanism(125A-800A MCCB)

Motor operating mechanism installation diagrams.

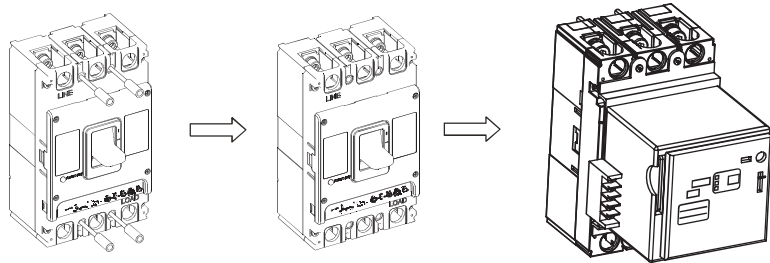

Installation dimension of motor operating mechanism and wiring diagram.

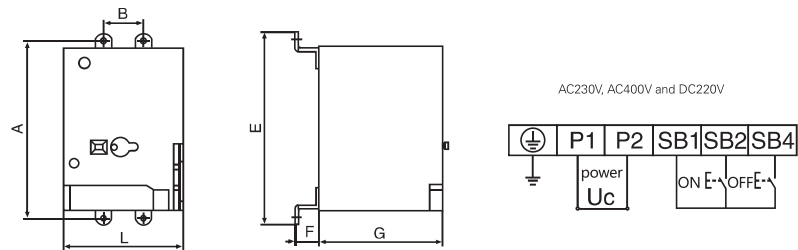

Unit: mm

Product	A	B	L	E	F	G
HDM3E-125/250	126	35	90.5	140	12	77
HDM3E-400/630	215	44	130	232	32	115
HDM3E-800	243	70	130	260	31	115

#### Note

- 1,When the breaker with motor operating mechanism trips, motor operating mechanism must be switched off before being switched on.
- 2,The breaker can be remoted control by motor operating mechanism.Only qualified people can remove motor operating mechanism when operating on USB connection and dial switch.

## HDM3E Molded Case Circuit Breaker(Electronic)

Accessory Installation  
Standard:IEC/EN 60947-2



### Fixed rear connection(125A-800A MCCB)

Installation dimension of fixed rear connection

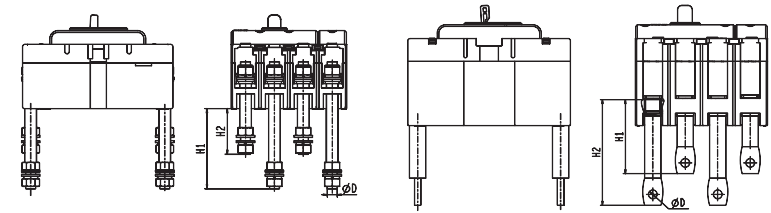

HDM3E-125/250

HDM3E-400/630/800

Unit: mm

Product	H1	H2	φD
HDM3E-125/250	102	72	10
HDM3E-400/630	92	128	12.5
HDM3E-800	129	129	13

Installation hole dimension of fixed rear connection

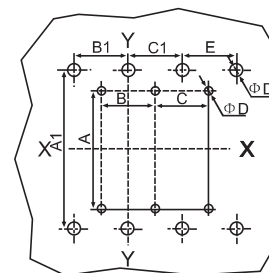

Note: X-X,Y-Y is the center of the three pole breaker

Unit: mm

Product	Pole	A	B	C	φD	A1	B1	C1	E	φD1
HDM3E-125/250	3	126	35	-	5.5	145	35	35	-	15
	4			35						
HDM3E-400/630	3	215	44	-	6.5	225	48	48	-	32
	4			48						
HDM3E-800	3	243	70	-	7.5	243	70	70	-	40
	4			70						

## HDM3E Molded Case Circuit Breaker(Electronic)

Accessory Installation  
Standard:IEC/EN 60947-2



### Plug-in front connection(125A-250A MCCB)

Installation dimension and installation hole dimension of plug-in front connection

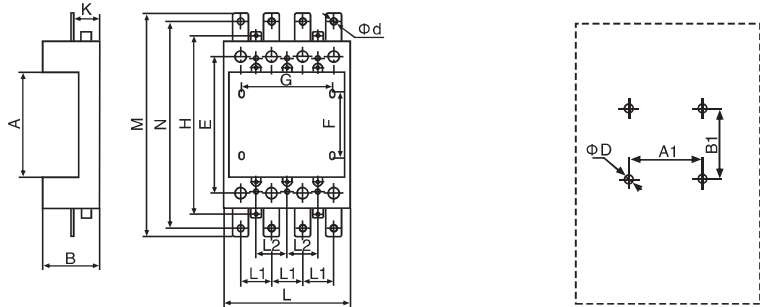

Installation dimension of plug-in connection

Installation hole dimension of plug-in connection

Unit: mm

Product	Pole	A	B	E	F	G	H	L	L1	L2	M	N	K	Φd	A1	B1	ΦD
HDM3E-125/250	3	108.5	73.2	144	74	70	191	105	35	35	243	223	37.5	8.5	35	150	5
	4							140									

## HDM3E Molded Case Circuit Breaker(Electronic)

Accessory Installation  
Standard:IEC/EN 60947-2



### Plug-in rear connection(125A-800A)

Installation dimension of plug-in rear connection

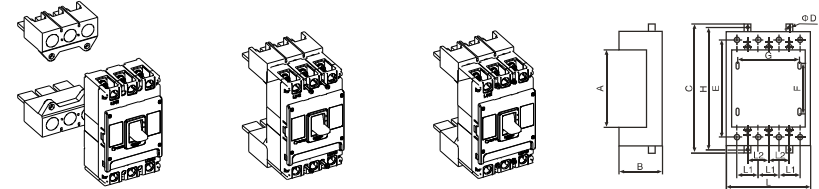

Installation diagram of plug-in rear connection accessory

Installation dimension of plug-in rear connection accessory

Unit: mm

Product	Pole	A	B	C	D	E	F	G	H	L	L1	L2
HDM3E-125/250	3	108.5	73.2	203	M4	144	74	70	191	105	35	35
	4							105				
HDM3E-400/630	3	170	60	-	-	225	130	60	-	152	48	44
	4							108		200		
HDM3E-800	3	187	125	342	M5	243	143	140	328	210	70	70
	4							210		280		

Installation hole dimension of plug-in rear connection accessory

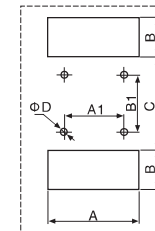

Unit: mm

Product	Pole	A	A1	B	B1	C	ΦD
HDM3E-125/250	3	110	70	45	74	100	6.5
	4	145	105				
HDM3E-400/630	3	157	88	60	145	170	8.5
	4	205	132				
HDM3E-800	3	212	140	64	143	185	11
	4	282	210				

## HDM3E Molded Case Circuit Breaker(Electronic)

Accessory Installation  
Standard:IEC/EN 60947-2



### Withdrawable connection(400~800 frame)

Installation dimension of withdrawable connection accessory

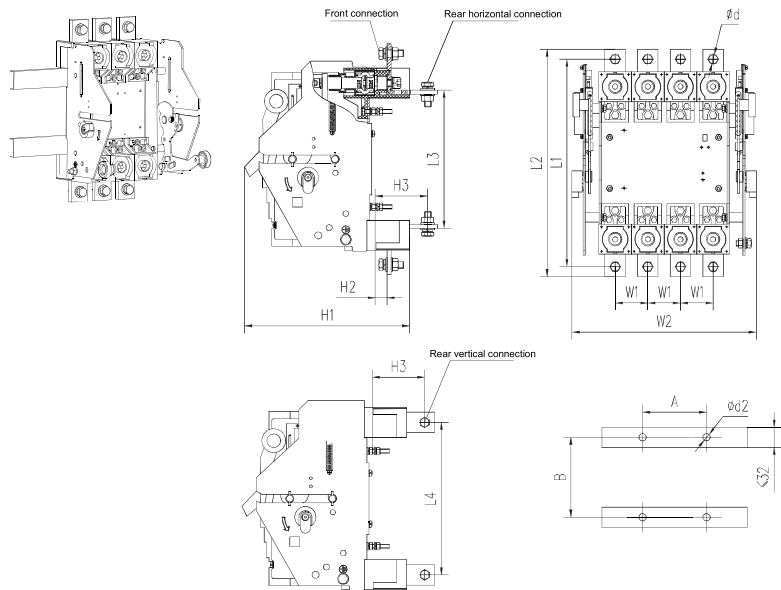

Product	Pole	Appearance dimension										Installation dimension		
		L1	L2	L3	L4	H1	H2	H3	W1	W2	φd1	A	B	φd2
HDM3E-400	3P	310	339	203	223	253	17.5	77	48	223	φ11	96	140	φ7
	4P	310	339	203	223	253	17.5	77	48	271	φ11	144	140	φ7
HDM3E-630	3P	310	339	207	223	253	17.5	77	48	223	φ11	96	140	φ7
	4P	310	339	207	223	253	17.5	77	48	271	φ11	144	140	φ7
HDM3E-800	3P	367	410	241	231	238	-26	73	70	289	φ13	140	131	φ7
	4P	367	410	241	231	238	-26	73	70	359	φ13	210	131	φ7

## HDM3E Molded Case Circuit Breaker(Electronic)

Accessory Installation  
Standard:IEC/EN 60947-2



Installation hole dimension of withdrawable connection

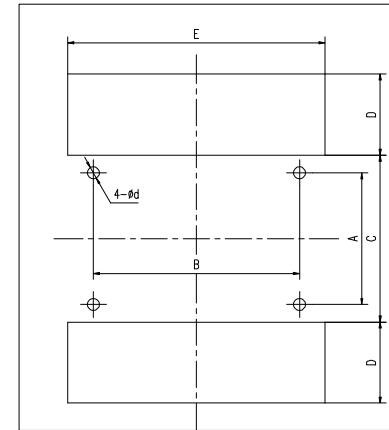

Product	Opening hole on plate							d
	A	B		C	D	E		
		3P	4P			3P	4P	
HDM3E-400	140	96	144	178	47	147	195	7
HDM3E-630	140	96	144	178	47	147	195	7
HDM3E-800	131	140	210	170	77	213	283	7

Note 1. 630A HDM3E need to reduce capacity to 500A to use withdrawable connection.  
2. If customer has no special requirement, withdrawable connection will not equip with electrical interlock



## HDM3E Molded Case Circuit Breaker(Electronic)

Accessory Installation  
Standard:IEC/EN 60947-2



### Accessories installation position(125A-800A MCCB)

□ Alarm contact    ■ Auxiliary contact    ● Shunt release    ○ Undervoltage release



Accessory code	Accessory name	Product type				
		HDM3E-125	HDM3E-250	HDM3E-400	HDM3E-630	HDM3E-800
308	Alarm contact (can be installed on the right or left side, default left side)	□ □ □	□ □ □	□ □ □	□ □ □	□ □ □
310	Shunt release (can be installed on the right or left side, default right side)	□ □ ●	□ □ ●	□ □ ●	□ □ ●	□ □ ●
320	Auxiliary contact (can be installed on the right or left side, default right side)	■ □ □	■ □ □	■ □ □	■ □ □	■ □ □
330	Undervoltage release	○ □ □	○ □ □	○ □ □	○ □ □	○ □ □
340	Shunt release + auxiliary contact	■ □ ●	■ □ ●	■ □ ●	■ □ ●	■ □ ●
350	Shunt release+ undervoltage release	○ □ ●	○ □ ●	○ □ ●	○ □ ●	○ □ ●
360	Two pieces of auxiliary contact (can be installed on the right or left side, default left side)	■ ■ □	■ ■ □	■ ■ □	■ ■ □	■ ■ □
370	Auxiliary contact+ undervoltage release	○ □ ■	○ □ ■	○ □ ■	○ □ ■	○ □ ■
318	Shunt release + alarm contact	□ □ ●	□ □ ●	□ □ ●	□ □ ●	□ □ ●
328	Auxiliary contact+alarm contact (can be installed on the right or left side, default left side)	□ ■ □	□ ■ □	□ ■ □	□ ■ □	□ ■ □
338	Undervoltage release+ alarm contact	○ □ □	○ □ □	○ □ □	○ □ □	○ □ □
348	Shunt release+ auxiliary contact+ alarm contact	□ ■ ●	□ ■ ●	□ ■ ●	□ ■ ●	□ ■ ●
368	Two piece of auxiliary contact +alarm contact	□ ■ ■	□ ■ ■	□ ■ ■	□ ■ ■	□ ■ ■
378	Auxiliary contact+undervoltage release+alarm contact	○ □ ■	○ □ ■	○ □ ■	○ □ ■	○ □ ■

## HDM3E Molded Case Circuit Breaker(Electronic)

Accessory Installation(1600A)  
Standard:IEC/EN 60947-2



### 1600A Inside accessories

Taking down the cover and secondary connection terminal.

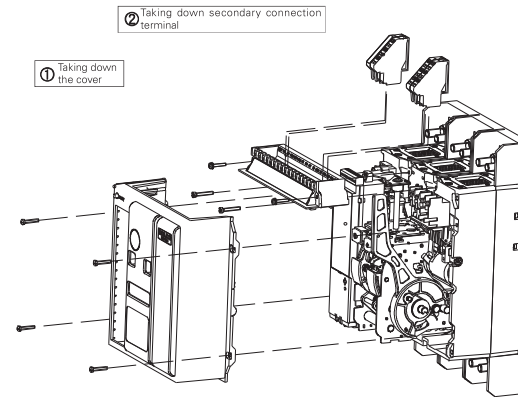

Danger:  
Make sure power supply shut down  
before installation

Installing coil,motor operating mechanism and auxiliary contact

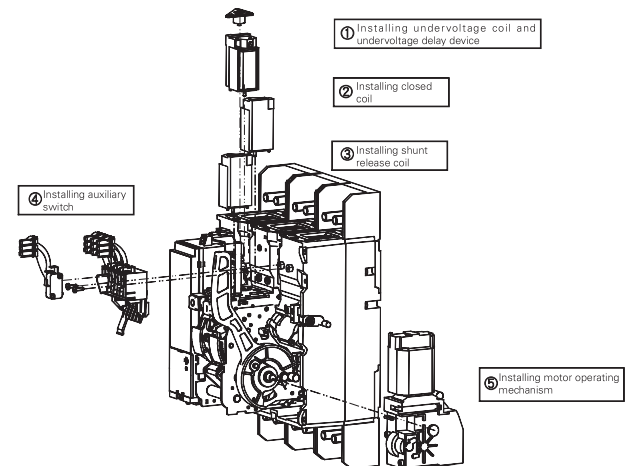

## HDM3E Molded Case Circuit Breaker(Electronic)

Accessory Installation(1600A)  
Standard:IEC/EN 60947-2



### 1600A Secondary circuit connection

#### Fixing auxiliary terminal

Fixed type  
Inserting auxiliary terminal into groove directly

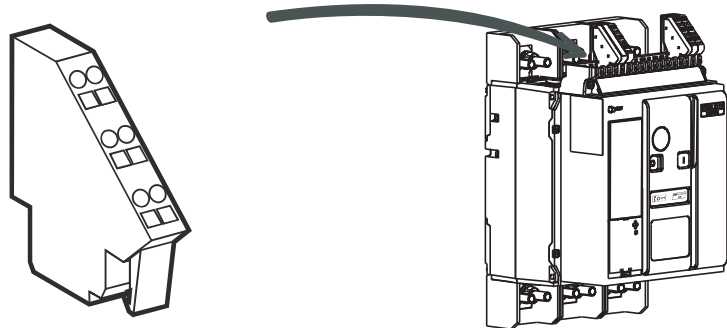

#### Terminal layout

DC24V

Res/SWT	UM	ZSI	Pow	SWT	Com	CT	MN	MX	XF	MCH	PF	OF4	OF3	OF2	OF1
	22	13/17	1	5	10	25	27	29	31	35		38	41	44	47
	23	16/19		3	12					33		36	39	42	45
	21/24	14/15	2	4	11	26	28	30	32	34		37	40	43	46
Control Unit						Remote Operating					Auxiliary Switch				

- 1 Check terminal serial number
- 2 Inserting same serial number of connection port
- 3 Pow 1,2 is DC24V power supply port, make sure use with DC 24V from factory. Note:DC24V can be positive and negative connection, do not access directly to 230V power

## HDM3E Molded Case Circuit Breaker(Electronic)

Accessory Installation(1600A)  
Standard:IEC/EN 60947-2



#### Wiring for auxiliary terminal

- mini S: 0.6mm<sup>2</sup>
- maxi S: 2.5mm<sup>2</sup>



#### Sectional area of wire

Min 0.6mm<sup>2</sup>

Max 2.5mm<sup>2</sup>

The stripper wire needs at least 8mm

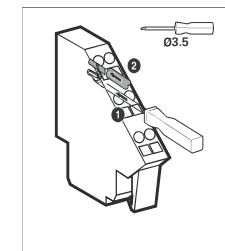

- 1 Insert screwdriver into the box and press down
- 2 Meanwhile insert wire into circle
- 3 Release screwdriver, make sure wire connect with auxiliary terminal

#### Transform installation

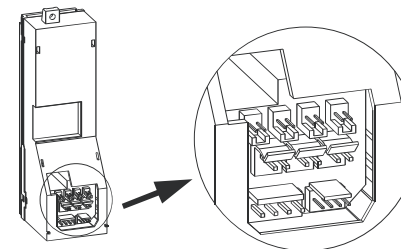

connect the transform with control unit terminal  
(match number in transform and control unit terminal)



## HDM3E Molded Case Circuit Breaker(Electronic)

Standard product type  
Standard:IEC/EN 60947-2



### 125A-800A MCCB

Standard products can be provided for 125-800A

Standard electronic, LSI triple protection.

- Each protection can be open and closed,can be set up for distribution or motor protection



### 1600A

2 standard product can be provided for 1600A

1.Standard electronic ,LSIG protection.

- Each protection can be open and closed except long time delay protection,can be set up for distribution or motor protection
- Control unit is 3E-1600,power supply module,alarm contact, auxiliary contact(2 NO 2 NC), interphase barriers

2.Four remote control and communication function,LSIG protection.

- Each protection can be open and closed except long time delay protection,can be set up for distribution or motor protection
- Equipped RS485, and support Modbus-RTU is communication protocol
- 1600 AF standard offer: power module(AC400V/DC24V); Auxiliary contact 2open2close; Alarm contact; 3E-T1600 controller; motor mechanism(including motor, shunt release, close coil),the voltage must be the same of the above accessory; signal transfer module; Interphase barriers



## HDM3E Molded Case Circuit Breaker(Electronic)

Product reference  
Standard:IEC/EN 60947-2



Order reference	Product description
HDM3E125M12533XX	HDM3E-125M 3 pole 125A
HDM3E250M25033XX	HDM3E-250M 3 pole 250A
HDM3E400M40033XX	HDM3E-400M 3 pole 400A
HDM3E630M63033XX	HDM3E-630M 3 pole 630A
HDM3E800M80033XX	HDM3E-800M 3 pole 800A
HDM3E16XM16X33XX	HDM3E-1600M 3 pole 1600A
HDM3E125M125C3XX	HDM3E-125M 4 pole 125A
HDM3E250M250C3XX	HDM3E-250M 4 pole 250A
HDM3E400M400C3XX	HDM3E-400M 4 pole 400A
HDHDM3E630M630D3X	HDM3E-630M 4 pole 630A
HDM3E800M800D3XX	HDM3E-800M 4 pole 800A
HDM3E16XM16XC3XX	HDM3E-1600M 4 pole 1600A



©2020 HIMEL

Himel  
[www.himel.com](http://www.himel.com)

May 2020

